

OWNER'S GUIDE & INSTALLATION INSTRUCTIONS

Thru-Hull, Metal Stem Depth Transducer

Models: B45, B46, B258, B260,
SS258, SS260, SS261, SS270W, SS505, SS560

IMPORTANT: Please read the instructions completely before proceeding with the installation. These instructions supersede any other instructions in your instrument manual if they differ.

CAUTION: NEVER USE SOLVENTS!

Cleaners, fuel, paint, sealants, and other products may contain strong solvents, such as acetone, which attack many plastics greatly reducing their strength.

Applications

- **Bronze** transducer recommended for fiberglass or wood hulls. *Never mount a bronze transducer in a metal hull, because electrolytic corrosion will occur.*
- **Stainless steel** transducer compatible with all hull materials. Recommended for aluminum hulls to prevent electrolytic corrosion provided the stainless steel transducer is isolated from the metal hull. **Caution:** Installation requires using a fairing kit to isolate the stainless steel transducer from a metal hull.
- *Never install a metal transducer on a vessel with a positive ground system.*

Tools & Materials

Safety goggles

Dust mask

Electric drill

Drill bits:

Pilot hole	3mm <i>or</i> 1/8"
B45, B46, SS505	22mm <i>or</i> 7/8"
B260, SS260, SS261, SS270W, SS560	33mm <i>or</i> 1-5/16"
B258, SS258	30mm <i>or</i> 1-3/16"

Sandpaper

Mild household detergent *or* weak solvent (such as alcohol)

File (installation in a metal hull)

Fairing (**MANDATORY FOR SS261 AND SS560**)

Angle finder *or* digital level (installation with a fairing)

Band saw *or* hand saw (installation with a fairing)

Rasp *or* power tool (installation with a fairing)

Marine sealant (suitable for below waterline)

Slip-joint pliers

Zip-ties

Water-based antifouling paint (**MANDATORY IN SALT WATER**)

Installation in a cored fiberglass hull: (see page 4)

Drill bit for hull interior:

B45, B46, SS505	35mm <i>or</i> 1-3/8"
B260, SS260, SS261, SS270W, SS560	42mm <i>or</i> 1-5/8"
B258, SS258	40mm, 41mm, <i>or</i> 1-5/8"

Cylinder, wax, tape, and casting epoxy

Record the information found on the cable tag for future reference.

PN: _____ Date _____ Frequency _____ kHz

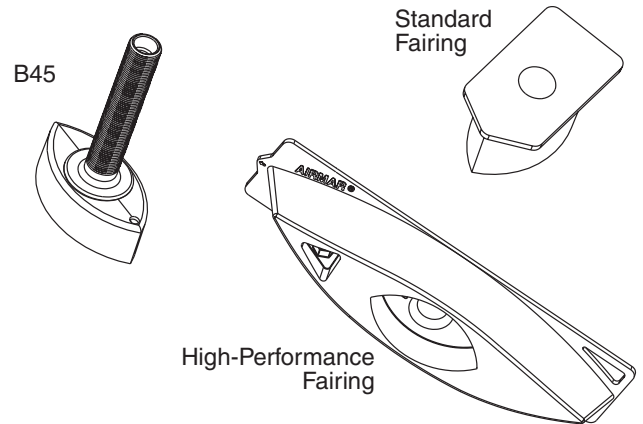

Identify Your Model

The model name is printed on the cable tag.

About Fairings

Nearly all vessels have some deadrise angle at the mounting location. If the transducer is mounted directly to the hull, the sound beam will be tilted to the side at the same angle as the deadrise. A fairing is strongly recommended if the deadrise angle exceeds 10°.

- Orients the sound beam straight down by mounting the transducer parallel to the water surface.
- Mounts the transducer deeper in the water for clean flow over the transducer's face.

Made of a high-impact polymer with an integrated cutting guide, an Airmar fairing is safer and easier to cut with a band saw and shape with hand tools than custom fairings. It can be shaped to accommodate a deadrise angle of up to about 25°. (For fairing part numbers, see "Replacement Parts" on page 4.)

A backing block is mounted inside the hull to provide a level surface for the hull nut to seat against (see Figure 2). It is fabricated matching the interior deadrise angle of the boat. After cutting an Airmar fairing, use the remaining section with the cutting guide for the backing block.

High-Performance Fairing has a long streamlined shape for excellent performance above 15kn (18MPH). (To order see "Replacement Parts" on page 4.)

Mounting Location

- The water flowing across the hull *must* be smooth with a minimum of bubbles and turbulence (especially at high speeds). **Caution:** *DO NOT MOUNT near water intake or discharge openings or behind strakes, fittings, or hull irregularities.*
- The transducer *must* be continuously immersed in water.
- The transducer beam *must* be unobstructed by the keel or propeller shaft(s).
- Choose a location away from interference caused by power and radiation sources such as: the propeller(s) and shaft(s), other

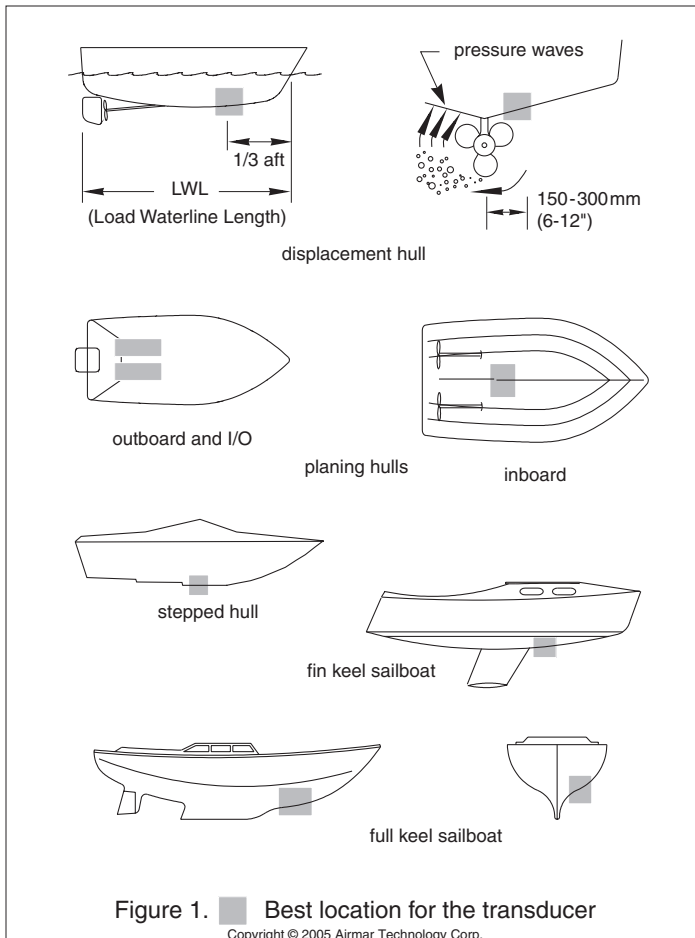

Installation—No fairing or Standard Fairing only

WARNING: A High-Performance Fairing must be installed following the Installation Instructions that come with the fairing. The High-Performance Fairing requires an anti-rotation bolt. Failure to install the anti-rotation bolt may result in the fairing rotating while the boat is underway. The effect may be violent movement and loss of steering. This could result in serious injury or death to passengers and/or damage to the boat or other property.

Installation with NO fairing—If installing a transducer without a fairing, disregard all references to a fairing and backing block.

Cored fiberglass hull—Follow separate instructions on page 4.

Hole Drilling

Warning: Always wear safety goggles and a dust mask.

1. Drill a 3mm or 1/8" pilot hole perpendicular to the waterline from inside the hull (see Figure 2). If there is a rib, strut or other hull irregularity near the selected mounting location, drill from the outside.
2. Using the appropriate size drill bit, cut a hole from outside the hull. *Be sure* to hold the drill plumb, so the hole will be perpendicular to the water surface.
3. Sand and clean the area around the hole, inside and outside, to ensure that the marine sealant will adhere properly to the hull. If there is any petroleum residue inside the hull, remove it with either a mild household detergent or a weak solvent (alcohol) before sanding.

Metal hull—Remove all burrs with a file and sandpaper.

Cutting the Standard Fairing

Warning: High-Performance Fairing—For your safety it is mandatory to follow the Installation Instructions that come with the fairing.

1. Measure the deadrise angle of the hull at the selected location using an angle finder or a digital level (see Figure 2)
2. Tilt the band saw table to the measured angle and secure the cutting fence (see Figure 3).

Caution: The **ARROW** always points forward toward the bow. (A symmetrical fairing can be oriented either way.) *Be sure* to orient the fairing on the band saw so the angle cut matches the intended side of the hull and not the mirror image.

machinery, other echosounders, and other cables. The lower the noise level, the higher the echosounder gain setting that can be used.

- Choose a location with a minimum deadrise angle.
- Choose an accessible spot inside the vessel with adequate headroom for the height of the stem and tightening the nut.

Boat Types (see Figure 1)

- **Displacement hull powerboat**—Locate 1/3 aft LWL and 150–300mm (6–12") off the centerline. The starboard side of the hull where the propeller blades are moving downward is preferred.
- **Planing hull powerboat**—Mount well aft near the centerline and *well inboard of the first set of lifting strakes* to insure that it is in contact with the water at high speeds. The starboard side of the hull where the propeller blades are moving downward is preferred.
 - Outboard and I/O**—Mount just forward and to the side of the engine(s).
 - Inboard**—Mount well ahead of the propeller(s) and shaft(s).
 - Stepped hull**—Mount just ahead of the first step.
 - Boat capable of speeds above 25kn (29MPH)**—Review transducer location and operating results of similar boats before proceeding.
- **Fin keel sailboat**—Mount to the side of the centerline and forward of the fin keel 300–600mm (1–2').
- **Full keel sailboat**—Locate amidships and away from the keel at the point of minimum deadrise angle.

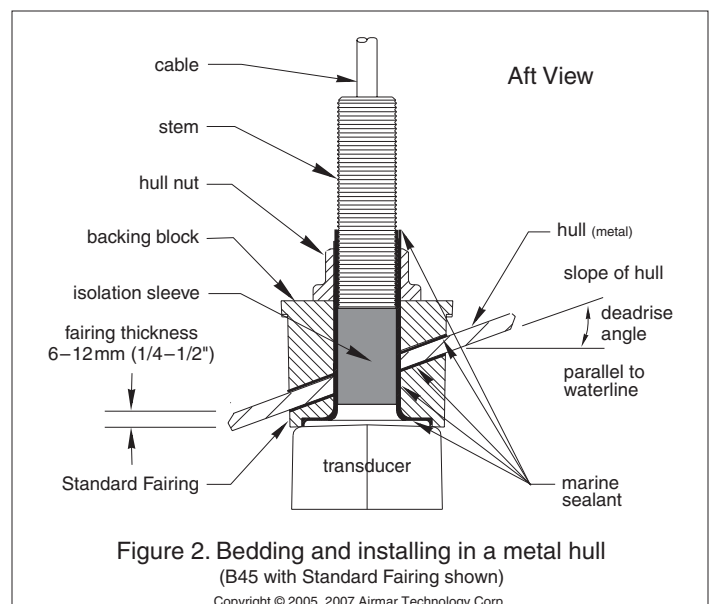

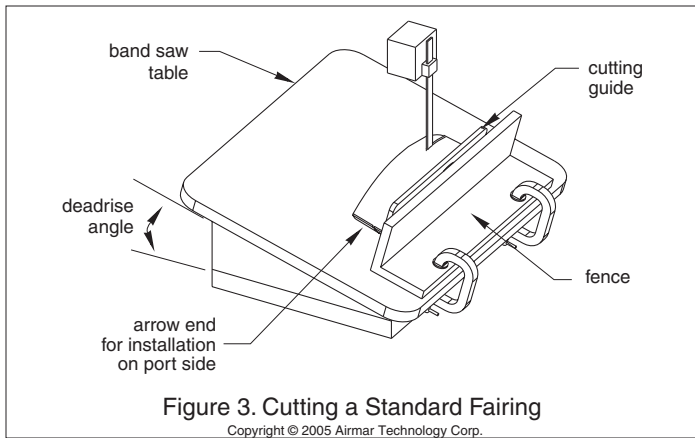

- Place the fairing on the table so the cutting guide rests against the fence. The arrow will be pointing toward you for installation on the port side and away from you for installation on the starboard side of the boat (see Figures 3 and 4).
 - Adjust the cutting fence. The fairing *must* be between 6–12mm (1/4–1/2") at its thinnest dimension (see Figure 2).
- Warning:** Always wear safety goggles and a dust mask.
- Recheck steps 1 through 4. Then cut the fairing.
 - Shape the fairing to the hull as precisely as possible with a rasp or power tool.
 - Use the remaining section of the fairing for the backing block.

Bedding

Caution: Never pull, carry, or hold the transducer by the cable as this may sever internal connections.

Caution: A stainless steel transducer/stem *must* be isolated from a metal hull to prevent electrolytic corrosion.

Warning: SS261 or SS560—A fairing is mandatory for strength.

- Remove the hull nut (see Figure 5).
- Thread the transducer cable through the fairing (if used).
- Apply a 2mm (1/16") thick layer of marine sealant around the sides of the transducer that will contact the hull/fairing and up the stem. The sealant *must* extend 6mm (1/4") higher than the combined thickness of the hull, fairing and backing block (if used), and the hull nut. This will ensure there is marine sealant in the threads to seal the hull and hold the hull nut securely in place. Also apply a 2mm (1/16") thick layer of marine sealant to the side of the hull nut that will contact the hull.

Stainless steel transducer/stem in a metal hull—Slide the isolation sleeve over the bedded transducer stem as far down as possible (see Figure 2). Apply a 2mm (1/16") thick layer of the marine sealant to the outside of the sleeving.

Standard Fairing—If a fairing is being used, seat the transducer firmly in/against the fairing with a pushing twisting motion. Apply a 2mm (1/16") thick layer of marine sealant to the surface of the fairing that will contact the hull and the surface of the backing block that will contact the hull (see Figure 5).

Installing

Caution: Never strike the transducer.

- From outside the hull, thread the cable through the mounting hole. Then push the stem of the transducer through the hole using a twisting motion to squeeze out excess sealant. *Take care to align the transducer with the blunt end facing the bow and the long side parallel to the centerline of the boat (see Figure 4).*
Standard Fairing—The arrow points forward toward the bow. (A symmetrical fairing can be oriented either way.)
Stainless steel transducer/ stem in a metal hull—Be sure the isolation sleeve is between the transducer stem and the hull (see Figure 2). However, the top of the isolation sleeve *must* be below the top of the hull nut or the backing block to prevent the sleeving from interfering with tightening the hull nut.
- From inside the hull, slide the backing block (if installing with a fairing) and hull nut onto the cable. Seat the backing block against the hull. Screw the hull nut in place and tighten it with slip-joint pliers (see Figure 2 or 5).
Wood hull—Allow for the wood to swell.
Cored fiberglass hull—Do not over-tighten crushing the hull.
- Remove any excess marine sealant on the outside of the hull/fairing to ensure smooth water flow over the transducer.
Caution: If the transducer came with a connector, do not remove it to ease cable routing. If the cable must be cut and spliced, use Airmar's splash-proof Junction Box No. 33-035 and follow the instructions provided. Removing the water-proof connector or cutting the cable except when using Airmar's junction box, will void the transducer warranty.
- Route the cable to the instrument *being careful* not to tear the cable jacket when passing it through the bulkhead(s) and other parts of the boat. To reduce electrical interference, separate the transducer cable from other electrical wiring and the engine. Coil any excess cable and secure it in place with zip-ties to prevent damage.
- Refer to the instrument owner's manual to connect the transducer to the instrument.

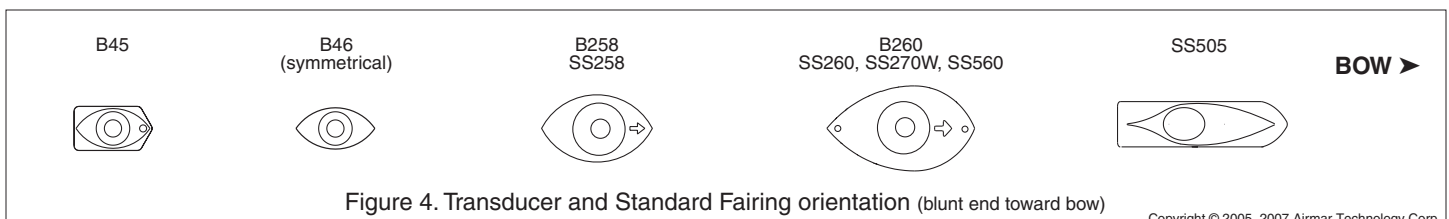
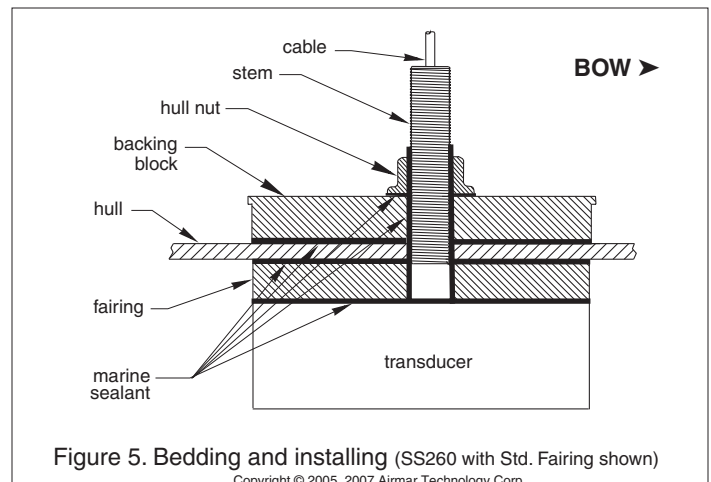

Checking for Leaks

Warning: *DO NOT* leave the boat in the water unchecked for several days.

When the boat is placed in the water, **immediately** check the thru-hull transducer for leaks. Note that very small leaks may not be readily observed. *Do not* leave the boat in the water for more than 3 hours before checking it again. If there is a small leak, there may be considerable bilge water accumulation after 24 hours. If a leak is observed, repeat "Bedding" and "Installing" **immediately** (see page 3).

Installation in a Cored Fiberglass Hull

The core (wood or foam) *must* be cut and sealed carefully. The core *must* be protected from water seepage, and the hull *must* be reinforced to prevent it from crushing under the hull nut allowing the transducer to become loose.

Warning: *Always wear safety goggles and a dust mask.*

1. Drill a 3mm or 1/8" pilot hole perpendicular to the waterline from inside the hull (see Figure 6). If there is a rib, strut, or other hull irregularity near the selected mounting location, drill from the outside. If the hole is drilled in the wrong location, drill a second hole in a better location. Apply masking tape to the outside of the hull over the incorrect hole and fill it with epoxy.
2. Using the appropriate size drill bit, cut a hole from outside the hull through the *outer* skin only. *Be sure* to hold the drill plumb, so the hole will be perpendicular to the water surface.
3. The optimal interior hole diameter is affected by the hull's thickness and deadrise angle. It must be large enough in diameter to allow the core to be completely sealed.

Using the appropriate size drill bit for the hull interior, cut through the *innerskin* and most of the core from inside the hull keeping the drill perpendicular to the hull. The core material can be very soft. Apply only light pressure to the drill bit after cutting through the *innerskin* to avoid accidentally cutting the *outerskin*.

4. Remove the plug of core material so the *inside* of the outer skin and the inner core of the hull is fully exposed. Sand and clean the inner skin, core, and the outer skin around the hole.

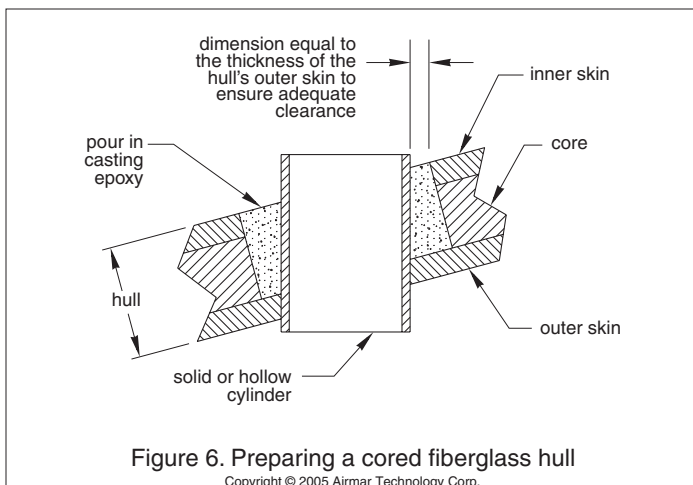

Caution: *Completely seal the hull to prevent water seepage into the core.*

5. Coat a hollow or solid cylinder of the correct diameter with wax and tape it in place. Fill the gap between the cylinder and hull with casting epoxy. After the epoxy has set, remove the cylinder.
6. Sand and clean the area around the hole, inside and outside, to ensure that the sealant will adhere properly to the hull. If there is any petroleum residue inside the hull, remove it with either mild household detergent or a weak solvent (alcohol) before sanding.
7. Proceed with "Bedding" and "Installing" on page 3.

Antifouling Paint

Surfaces exposed to salt water *must* be coated with antifouling paint. Use water-based antifouling paint only. *Never* use ketone-based paint since ketones can attack many plastics possibly damaging the transducer. Reapply antifouling paint every 6 months or at the beginning of each boating season.

Maintenance, Parts & Replacement

Cleaning

Aquatic growth can accumulate rapidly on the transducer's surface reducing its performance within weeks. Clean the surface with a Scotch-Brite® scour pad and mild household detergent taking care to avoid making scratches. If the fouling is severe, lightly wet sand with fine grade wet/dry paper.

Replacement Parts

The information needed to order a replacement transducer is printed on the cable tag. *Do not* remove this tag. When ordering, specify the part number, date, and frequency in kHz. For convenient reference, record this information on the top of page 1.

Model	Hull Nut	Fairing Type	Fairing
B45	02-031-3	Standard	33-351-01
		High-Performance	33-352-02
B46	02-031-3	Standard	33-020
		High-Performance	33-359-01
B258	02-222-03	Standard	33-226-01
		High-Performance	33-523-01
SS258	02-539-01	Standard	33-226-01
		High-Performance	33-523-01
B260	02-036-2	Standard	33-030
		High-Performance	33-391-01
SS260, SS270W	02-036-03	Standard	33-030
		High-Performance	33-391-01
SS261	02-036-03	High-Performance	04-645-02
SS505	02-111-01	High-Performance	33-355-01
SS560	03-169	High-Performance	33-466-01

Obtain parts from your instrument manufacturer or marine dealer.

Gemeco (USA)	Tel:	843.394.3565
	Fax:	843.394.3736
	email:	sales@gemeco.com
Airmar Europe	Tel:	+45.45.81.04.18
	Fax:	+45.45.81.04.93
	email:	sales@airmareurope.com