



# Low Profile

## P19 • B22

The P19 and B22 models have been the standard in low profile models for many years. Their large, sensitive ceramics allow deep echosounding up to 206 m (700'). These nearly flush units minimize drag as only 5 mm (3/16") of the housing extends outside of the hull.

### Features:

- Right angle cable exit reduces required headroom and protects the cable from damage
- Available as molded plastic P19 model or robust bronze B22 model
- Housings are ABYC H-27 compliant
- Included rubber washer (part # 09-452) allows tightening of the hull nut to irregular hull surfaces



Hull material:  
Fiberglass- P19, B22  
Wood- B22  
Aluminum- P19  
Photo: P19

Frequencies:	Beam Width: (@-3dB)	Rated RMS Power: (W)	Figure of Merit: (dB)	Q:
200kHz-U	11°	375W	-22	22
235kHz-B	11°	350W	-21	25
Acoustic Window:	Urethane			
Weight:	P19 molded plastic: B22 cast bronze:		0.5 kg (1.1 lb.) 0.9 kg (2.0 lb.)	
Hull Deadrise Angle:	0° – 12° optimum 20° maximum			
Hole Diameter for Installation:	51mm (2")			

### Performance:

	200kHz-U	235kHz-B		
Depth Range	147m – 206m 500' – 700'	147m – 176m 500' – 600'		

**Also see:**  
ST800, ST650 for matching speed/temp  
P219, P269, B119, B21



# Low Profile

## P19 • B22

### Applications:

- Cruising powerboats and sailboats
- Sailboats

### Notes:

- No additional notes

### Options:



- Temperature sensor

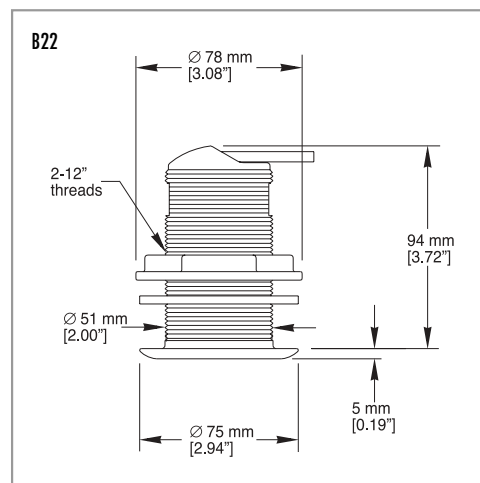
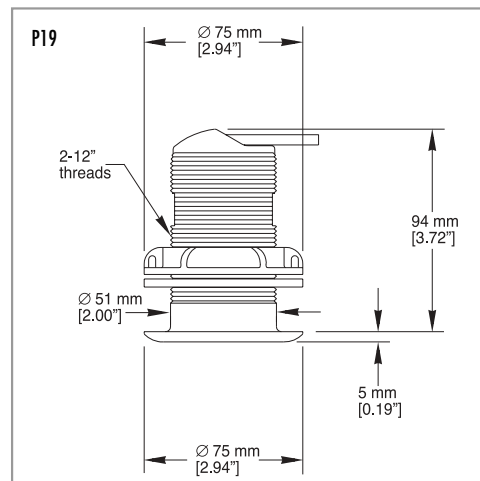

B22

### Parts & Accessories:



Plastic Hull Nut:  
P19: 04-004



Bronze Hull Nut:  
B22: 02-030