



Speed, Temperature Low-Profile

ST850

The ST850 sensors are our standard thru-hull speed sensors. The plastic P617V, bronze B17 and stainless steel SS577 outer housing options are available to meet all hull requirements. These low profile housings are nearly flush and minimize drag with only 5 mm (3/16") extending outside of the hull.

Features:

- Self-closing valve eliminates flow of water into the hull when paddlewheel insert is removed for easy service or storage
- Patented valve assembly retrofits older S100, S500, and S550 models without having to haul a vessel
- Housings are ABYC H-27 compliant
- Fins alongside the paddlewheel provide flow stability for accurate readings at low speeds and in cross flow conditions



Hull material:
Fiberglass—B17, P617V, SS577
Wood—B17, SS577
Aluminum—P617V, SS577
Photo: SS577

Nominal Pulse Rate:	Per Nautical Mile	Per Knot
With Fins:	17,000 pulses	4.8 Hz
Without Fins:	19,000 pulses	5.3 Hz
Supply Voltage:	5-25 VDC	
Weight:	P617V molded plastic: 0.7 kg (1.4 lb) B17 cast bronze: 1.3 kg (2.8 lb) SS577 stainless steel: 1.6 kg (3.5 lb)	
Hole Diameter for Installation:	51 mm (2")	

Performance:

Speed Range	2 to 45 knots (2 to 52 MPH)			

Also see:

ST850 Flush-Mount
P17, B17, SS577 Retractable Depth

U.S. Patent No.: 4,898,029 • U.S. Patent No.: 5,186,050 • Australian Patent No.: 605,281
Canadian Patent No.: 1,313,775 • Japanese Patent No.: 1851014





Speed, Temperature Low-Profile

ST850

Applications:

- Planing hull powerboats
- Cruising sailboats

Notes:

- Included rubber washer
- Blanking plug is supplied with each unit
- of the hull nut to irregular hull surfaces

Options:



- Intelligent circuitry for linearity correction and jitter control
- Remove fins alongside paddlewheel
- Two-wire speed circuit
- Pulse division circuitry for other pulse rates
- Over-voltage protection (OVP)
- Bronze cap nut for bronze housing #02-031-01

Parts & Accessories:



Hull or Cap Nut:
P617V Cap: **04-234-1**

B17 Cap: **02-131-01**
rev05

SS577 Cap: **02-529**
rev02

P617V Hull: **04-004**
rev04

B17 Hull: **02-030**
rev06



Blanking Plug:
33-376-01 rev01



Paddlewheel Kit:
33-415 rev09



Housing & Nut:
P617V: **33-417**
rev03

B17: **33-100**
rev02

SS577: **33-094-01**
rev04

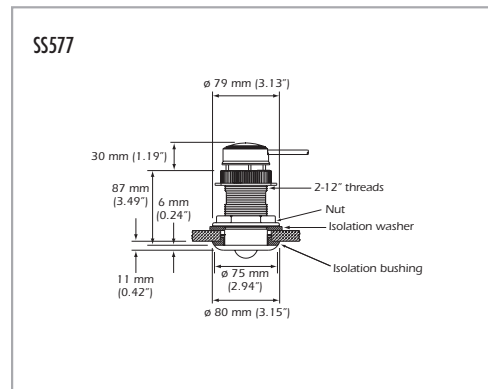
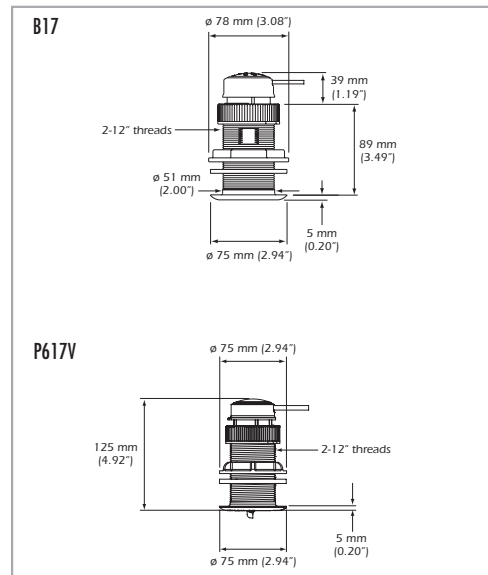

B17



P617V

