

OWNER'S GUIDE & INSTALLATION INSTRUCTIONS

In-Hull, 1 kW

Transducer

Models: M260, M265LH, M265LM

U.S. Patent No. 7,369,458. UK Patent No. 2 414 077. U.S. Patent Pending

11/11/10

17-446-01 r03

WARNING: Always wear safety goggles and a dust mask to avoid personal injury.

CAUTION: The fiberglass hull below the transducer must be solid. The transducer will not transmit through coring material such as foam or balsa wood.

CAUTION: Never pull, carry, or hold the transducer by the cable. This may sever internal connections.

CAUTION: Never use solvents. Cleaners, fuel, sealants, paint, and other products may contain strong solvents, such as acetone, which attack many plastics, greatly reducing their strength.

IMPORTANT: Please read the instructions completely before proceeding with the installation. These instructions supersede any other instructions in your instrument manual if they differ.

Record the information found on the cable tag for future reference.

Part No. _____ Date _____ Frequency _____ kHz

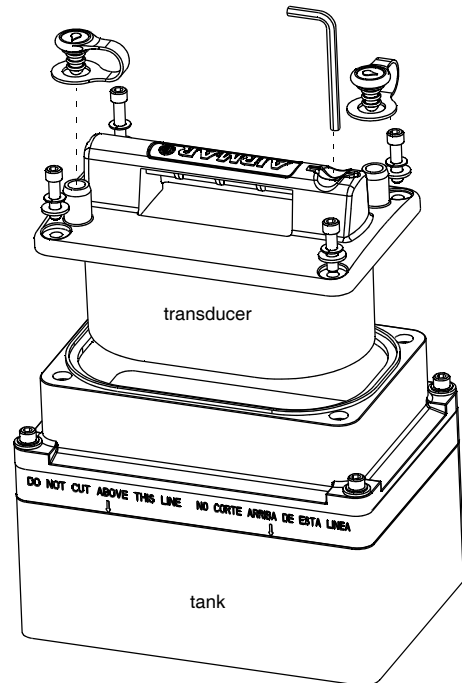

Figure 1. Exploded view (M260 shown)

Applications

- Fiberglass hulls only
- Recommended for high-speed boats
- Accommodates a deadrise angle up to 30° with the longest side of the tank installed parallel to the centerline (keel) of the hull.

Tools & Materials

- Safety goggles
- Dust mask
- Rope
- Detergent (some installations)
- Weak solvent (such as alcohol)
- Disk sander (some installations)
- Thin sealable plastic bag (some installations)
- Cable ties (some installations)
- Water-based lubricant (such as K-Y® jelly) (some installations)
- Carpenter's level
- Pencil
- Saw
- Scissors
- Sand paper: 80 grit

Bonding material (see www.airmar.com for additional brands):

Fiberglass resin: Bondo 401
West Marine #1937762

or Marine-Tex epoxy putty (14 oz. pack)
or 3M™ Marine Adhesive/Sealant 5200

Propylene glycol (non-toxic anti-freeze/coolant)
Grommet(s) (some installations)

Mounting Location

About Fiberglass Hulls

Since the hull absorbs acoustic energy, transmitting through the hull reduces the transducer's performance. Fiberglass hulls are often cored in places for added strength or to reduce weight. These cored areas contain balsa wood or structural foam which are poor sound conductors. **Do not locate the transducer over coring.**

Choose a Location

- Where the fiberglass is solid (no air bubbles are trapped in the fiberglass resin) and where no coring, flotation material, or dead air space is sandwiched between the inside skin and outer skin of the hull.
- Where the hull below the transducer will be in contact with the water at all times.
- Where the water flowing under the hull is smoothest with a minimum of bubbles and turbulence (especially at high speeds). Do not mount the transducer near water intake or discharge openings; or behind strakes, fittings, or hull irregularities.
- Where the transducer beam will not be blocked by the keel or propeller shaft(s).
- Away from interference caused by power and radiation sources such as: the propeller(s) and shaft(s), other machinery, other echosounders, and other cables. The lower the noise level, the higher the echosounder gain setting that can be used.
- Where the deadrise angle of the hull does not exceed 30°.
- Where there is space inside the vessel for the size of the tank and removing the transducer.

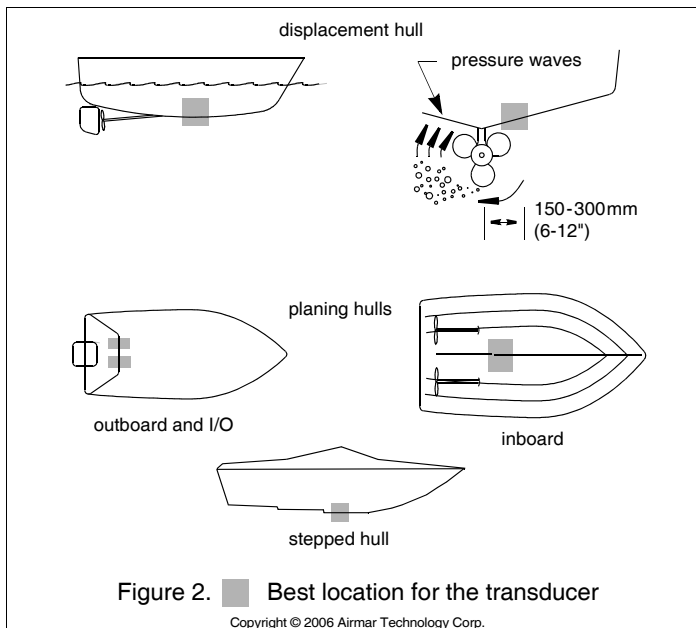

Boat Types (see Figure 2)

- **Displacement hull powerboats**—Locate amidships near the centerline. The starboard side of the hull where the propeller blades are moving downward is preferred.
- **Planing hull powerboats**—Mount well aft, on or near the centerline, and well inboard of the first set of lifting strakes to ensure that the transducer will be in contact with the water at high speeds. The starboard side of the hull where the propeller blades are moving downward is preferred.
 - Outboard and I/O**—Mount just forward of the engine(s).
 - Inboard**—Mount well ahead of the propeller(s) and shaft(s).
 - Stepped hull**—Mount just ahead of the first step.

Testing the Selected Mounting Location

Establishing a Performance Baseline

The results of this test are used as a basis of comparison to determine the best in-hull location for the transducer.

1. Take the boat to the maximum depth in which you will be operating the echosounder. If deep water is not available, find a location with at least 30m (100').
2. Connect the transducer to the echosounder.
3. Tie a rope securely around the handle of the transducer (see Figure 3). Lower it over the side of the boat until the active face is fully submerged and parallel to the water surface.
4. Observe the echosounder's performance and the depth reading.

Testing the Location

While the boat is at the same site (depth of water), test the transducer inside the hull at the mounting location. Use one of the test methods below:

- A. If the transducer will be located near the stern and the boat has a minimum deadrise angle**—Clean away any build-up of dirt and/or grease using detergent or a weak solvent such as alcohol. Place the transducer against the hull and flood the area with bilge water to cover the surface where they touch (see Figure 4-A).
- B. For a moderate deadrise angle**—If the hull surface is not smooth, grind it with a disc sander. Place the transducer inside a thin plastic bag. Partially fill the bag with water and close it tightly with a cable tie. Wet the surface of the hull and press the active face of the transducer against it through the bag (see Figure 4-B).
- C. For any location**—If the hull surface is not smooth, grind it with a disc sander. Coat the active face of the transducer with a water-based lubricant (such as K-Y® jelly). With a twisting motion, press the face firmly against the hull (see Figure 4-C). After testing, wipe away all traces of the lubricant from the transducer's face.

Observe the echosounder's performance and compare it to the baseline. Look for a stable depth reading that is similar to the baseline. Compare the thickness and intensity of the bottom trace.

If the performance is close to the baseline, this is a good mounting location. Remember, some energy is lost transmitting through the hull. If the test reading differs markedly from the baseline, you will need to find another location to install the transducer.

NOTE: If there is no reading or it is erratic, the transducer may be positioned over coring which is absorbing the acoustic energy. Choose another location. If no other location is available, check with the boat manufacturer to be certain coring is present.

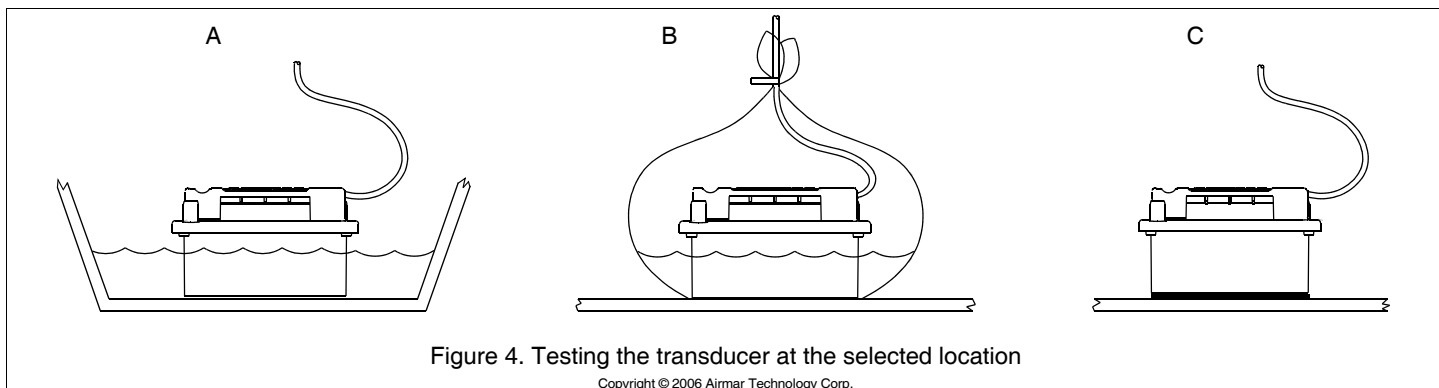
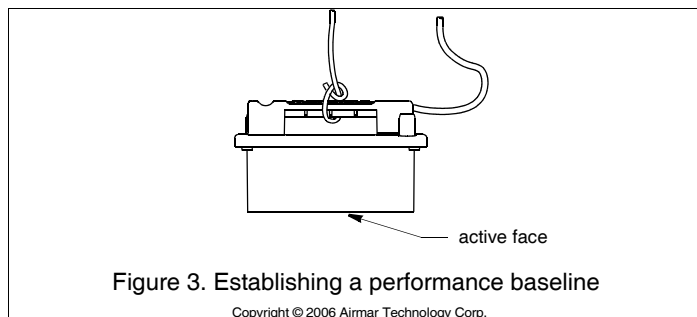

Installation

Marking & Cutting

CAUTION: For optimal performance, the transducer must be installed so the beam will be aimed straight down. This is accomplished by cutting the tank to match the deadrise angle of the hull.

CAUTION: Do not mark or cut the tank in the space labeled "Do not cut above this line."

1. The tank can be disassembled for installation in tight places. *Do not disassemble the tank unless it is necessary.* If the tank will be installed as one unit, lightly tighten the socket-head cap screws that hold the two halves of the tank together using the Allen wrench supplied (see Figure 1). (Use a blade screwdriver to remove the Allen wrench from the handle of the transducer. After use, replace the Allen wrench in the recess.)

2. When you are satisfied that the selected mounting location is optimal, place the tank *up-side-down* on the hull (see Figure 5).

NOTE: The tank can be placed with either a short side or a long side parallel to the centerline of the boat.

3. Holding a carpenter's level even with the *lower* corner of one of the sides to be cut, draw a *level* line on the tank. Repeat this process on the opposite side of the tank. *Connect the two lines to form the SHORTEST side of the tank.* Be sure the lines are level, as they will be the cutting guidelines.

4. *Before cutting the tank, be sure the TALLEST side will be closest to the centerline (keel) of the boat after the tank is installed.* And be sure to observe the "Do not cut above this line." Using a saw, cut the three sides of the tank along the guidelines drawn. It may be necessary to further shape the tank to the hull to ensure a liquid-tight bond.

5. The tank is provided with a cork liner to reduce sound echoes. After the tank has been cut, wrap the cork liner around the *inside* of the tank (see Figure 6). Butt the sides of the liner along the center of the tallest side. Push the cork liner up against the top edge on the inside of the tank. Trace the bottom edge of the tank onto the liner.

NOTE: There may be a gap between the butted edges which will not affect performance.

6. Remove the cork liner from the tank. Use scissors to cut the liner along the line drawn.

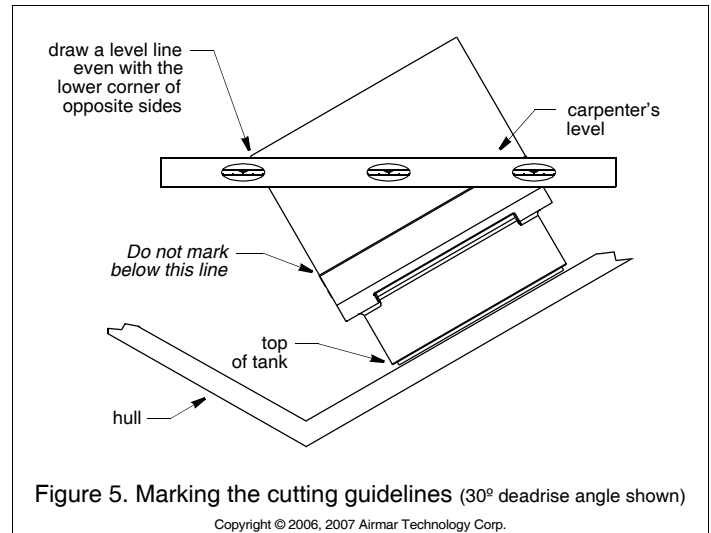
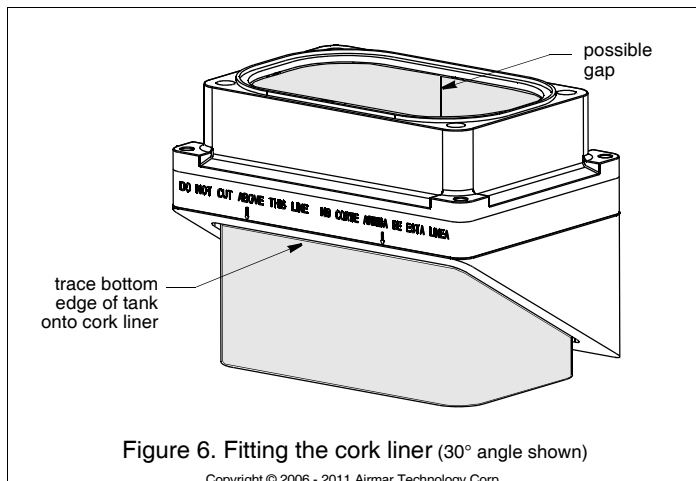

Bonding the Tank

CAUTION: The tank must be liquid-tight. To ensure a tight bond, the hull surface under and around the tank must be smooth, free of paint or any other finish, clean, and dry.

1. To ensure a tight bond, remove any paint or other hull finish. If the surface is rough, use a disk sander to smooth an area slightly larger than the tank. Clean any dust, grease, or oil from the hull surface with a weak solvent, such as alcohol. Dry the effected area.
2. Use 80 grit sand paper to sand the outside and inside of the tank up 50mm (2") above the bottom edge. Remove the dust with a weak solvent, such as alcohol. Dry the effected area.
3. Use an approved bonding material (see Tools & Materials on page 1). Glass the tank to the hull with fiberglass resin, using standard fiberglass technique. Alternatively, apply a generous bead of marine putty/sealant to the bottom edge of the tank following the manufacturer's instructions (see Figure 7). Press the tank firmly in place. Apply a second bead around the inside of the tank. And apply a third bead around the outside of the tank.
4. Allow the bonding material to cure. The seal must be liquid-tight.
5. If the tank is being installed in two parts, reattach the two sections now (see Figure 8). Be sure the O-ring gasket is in place around the lip and lubricated. Screw the two halves together using the socket-head cap screws, lock washers, and washers supplied. **Do not over tighten.**

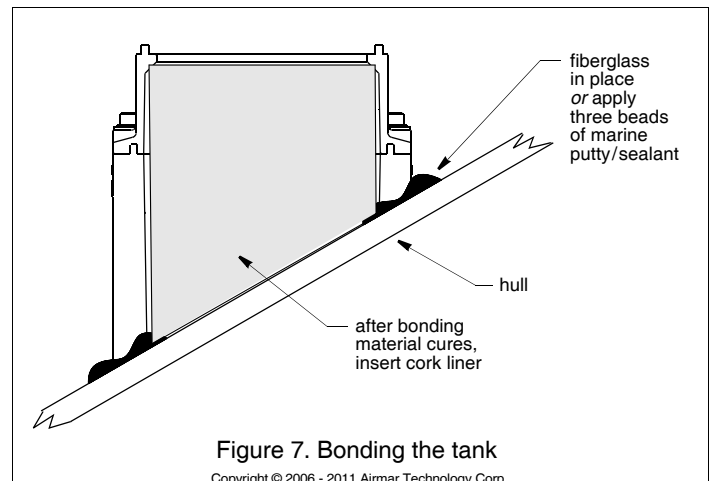

Installing the Transducer

CAUTION: Do not use sealant or adhesive on the gasket. To do so may break the tank when the transducer is removed.

CAUTION: Do not over-tighten the bolts to avoid cracking the tank.

1. After the bonding material has cured, insert the cork liner into the tank (see Figure 7). Butt the edges along the center of the tallest side. Note, there may be a gap, but this will not affect performance.
2. Following the manufacturer's directions for use, pour propylene glycol into the tank until it covers the exposed hull.
3. Before installing the transducer, wipe it clean of any lubricant that was used in testing the location. Check that the O-ring gasket is in the groove around the lip of the transducer.
4. Grasp the transducer by the handle and lower it into the tank (see Figure 8). There is no fore or aft to the transducer; it fits either way.
M265LH/LM—Be careful lowering the transducer. The metal plate on each side make a snug fit against the tank opening.
5. Attach the transducer to the tank. Use the four socket-head cap screws, four lock washers, and four washers supplied. Lightly tighten with the Allen wrench supplied. (Use a blade screwdriver to remove the Allen wrench from the handle of the transducer. Replace the Allen wrench in the recess in the handle.)
6. Top-off the propylene glycol in the tank. However, allow a small air space to accommodate expansion with temperature changes. Using the funnel supplied, pour the fill-liquid through one of the fill/vent holes until the tank is full (see Figure 9). The second hole will act as a vent. (Alternately, the tank can be filled using standard diameter tubing secured with a band clamp.) Attach the stoppers supplied and plug both fill/vent holes (see Figure 8). To ease sliding, lubricate the stoppers with the fill liquid. Tie the funnel to the handle to keep it near-at-hand.

Cable Routing & Connecting

CAUTION: If the transducer came with a connector, do not remove it to ease cable routing. If the cable must be cut and spliced, use Airmar's splash-proof Junction Box No. 33-035 and follow the instructions provided. Removing the water-proof connector or cutting the cable, except when using water-tight junction box, will void the transducer warranty.

1. Route the cable to the echosounder being careful not to tear the cable jacket when passing it through the bulkhead(s) and other parts of the boat. Use grommets to prevent chafing. To reduce electrical interference, separate the transducer cable from other electrical wiring and the engine(s). Coil any excess cable and secure it in place with cable ties to prevent damage.
2. Refer to your echosounder owner's manual to connect the transducer to the instrument.

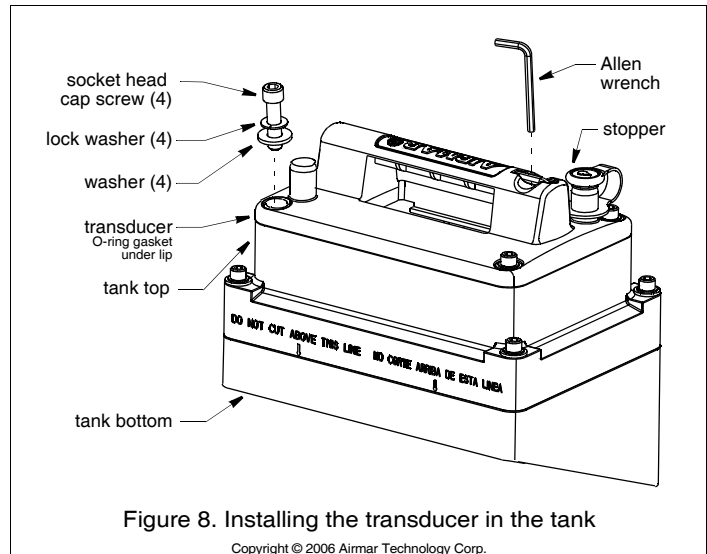

Figure 8. Installing the transducer in the tank

Copyright © 2006 Airmar Technology Corp.

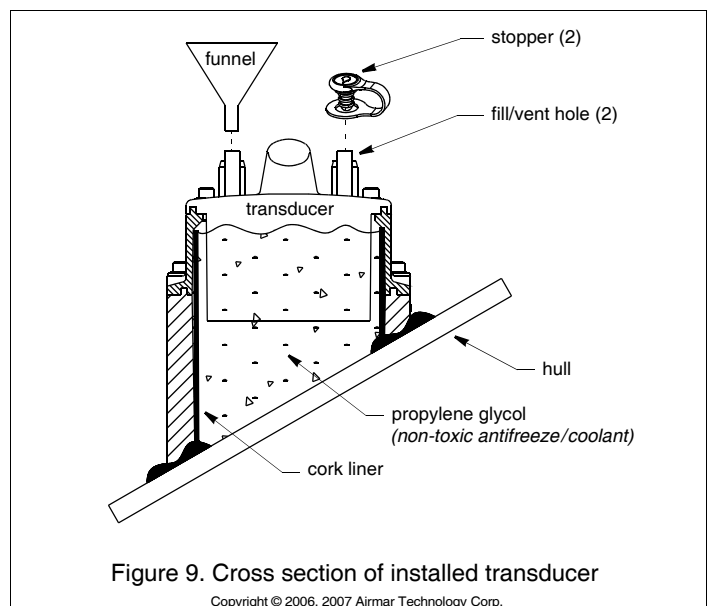

Figure 9. Cross section of installed transducer

Copyright © 2006, 2007 Airmar Technology Corp.

Replacement Transducer & Parts

The information needed to order a replacement Airmar transducer is printed on the cable tag. Do not remove this tag. When ordering, specify the part number, date, and frequency in kHz. For convenient reference, record this information at the top of page one.

Lost, broken, or worn parts should be replaced immediately.

In-Hull Mounting Kit 33-539-01

Obtain parts from your instrument manufacturer or marine dealer.

Gemeco Tel: 803-693-0777
(USA) Fax: 803-693-0477
email: sales@gemeco.com

Airmar EMEA Tel: +33.(0)2.23.52.06.48
(Europe, Middle East, Africa) Fax: +33.(0)2.23.52.06.49
email: sales@airmar-emea.com

AIRMAR[®]
TECHNOLOGY CORPORATION

35 Meadowbrook Drive, Milford, New Hampshire 03055-4613, USA
www.airmar.com