

# ACM100 *Alternating Current Monitor*

Maretron's ACM100 is a device which monitors AC power sources and outputs information about these sources onto the industry standard NMEA 2000® marine data network. ACM100 output information is then displayed with networked NMEA 2000® equipment such as the Maretron DSM250 dedicated display or with NMEA 2000® compatible software such as Maretron N2KView®.



## Products

PART NUMBER	DESCRIPTION
ACM100-01 M000630	Alternating Current (AC) Monitor ACM100 Current Transducer



- NMEA 2000® Interface
- Waterproof Connectors
- Sealed Waterproof Enclosure
- Opto-Isolated from NMEA 2000® Eliminating Potential Ground Loops
- Monitoring of busses carrying AC power and transmitting:
  - Voltage
  - Frequency
- Monitoring AC Power Sources such as Utilities and Generators and transmitting:
  - Voltage
  - Current
  - Frequency
  - Real Power
  - Reactive Power
  - Apparent Power
  - Power Factor
  - Total Energy Imported
  - Total Energy Exported

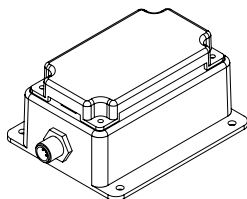
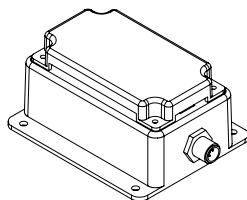
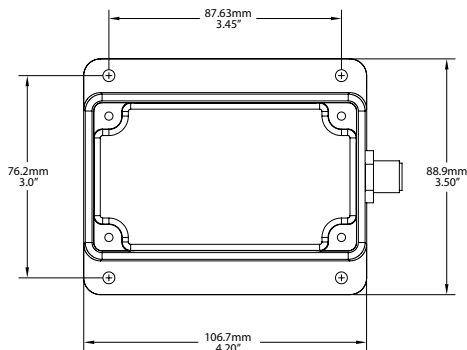
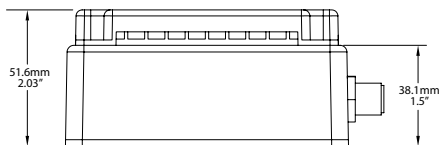

**Specifications**

Parameter	Value	Comment
Measurement Voltage Range	0 to 240VAC	AC Voltage
Measurement Voltage Accuracy	± 1%	0 to 240 VAC
Measurement Current Range	0 to 200A	With included current transformer
Measurement Current Accuracy	± 1%	With included current transformer

**Certifications**

Standard	Comment
NMEA 2000® Standard	Level A
Maritime Navigation and Radio Communication Equipment & Systems	IEC 61162-3
Maritime Navigation and Radio Communication Equipment & Systems	IEC 60945
FCC and CE mark	Electromagnetic Compatibility

**NMEA 2000® Parameter Group Numbers (PGNs)**

Description	PGN #	PGN Name	Default Rate	
Periodic Data PGNs	65001	Bus #1 Phase C Basic AC Quantities	10 times/second	
	65002	Bus #1 Phase B Basic AC Quantities	10 times/second	
	65003	Bus #1 Phase A Basic AC Quantities	10 times/second	
	65004	Bus #1 Average Basic AC Quantities	10 times/second	
	65005	Utility Total AC Energy	10 times/second	
	65006	Utility Phase C AC Reactive Power	10 times/second	
	65007	Utility Phase C AC Power	10 times/second	
	65008	Utility Phase C AC Basic Quantities	10 times/second	
	65009	Utility Phase B AC Reactive Power	10 times/second	
	65010	Utility Phase B AC Power	10 times/second	
	65011	Utility Phase B AC Basic Quantities	10 times/second	
	65012	Utility Phase A AC Reactive Power	10 times/second	
	65013	Utility Phase A AC Power	10 times/second	
	65014	Utility Phase A AC Basic Quantities	10 times/second	
	65015	Utility Total AC Reactive Power	10 times/second	
	65016	Utility Total AC Power	10 times/second	
	65017	Utility Average Basic AC Quantities	10 times/second	
	65018	Generator Total AC Energy	10 times/second	
	65019	Generator Phase C AC Reactive Power	10 times/second	
	65020	Generator Phase C AC Power	10 times/second	
	65021	Generator Phase C AC Basic Quantities	10 times/second	
	65022	Generator Phase B AC Reactive Power	10 times/second	
	65023	Generator Phase B AC Power	10 times/second	
	65024	Generator Phase B AC Basic Quantities	10 times/second	
	65025	Generator Phase A AC Reactive Power	10 times/second	
	65026	Generator Phase A AC Power	10 times/second	
	65027	Generator Phase A AC Basic Quantities	10 times/second	
	65028	Generator Total AC Reactive Power	10 times/second	
	65029	Generator Total AC Power	10 times/second	
	65030	Generator Average Basic AC Quantities	10 times/second	
	Response to Requested PGNs	126464	PGN List (Transmit and Receive)	N/A
		126996	Product Information	N/A
126998		Configuration Information	N/A	
Protocol PGNs	059392	ISO Acknowledge	N/A	
	059904	ISO Request	N/A	
	060928	ISO Address Claim	N/A	
	065240	ISO Address Command	N/A	
	126208	NMEA	N/A	
Maretron Proprietary PGNs	128720	Configuration	N/A	

**Electrical**

Parameter	Value	Comment
Operating Voltage	9 to 36 Volts	DC Voltage
Power Consumption	100 mA	NMEA 2000@v Interface
Load Equivalence Number (LEN)	2	NMEA 2000® Spec. (1LEN = 50 mA)
Reverse Battery Protection	Yes	Indefinitely
Load Dump Protection	Yes	Energy Rated per SAE J1113

**Mechanical**

Parameter	Value	Comment
Size	3.50" x 4.20" x 2.03" (88.9mm x 106.7mm x 51.6mm)	Excluding NMEA 2000® Connector & Cable
Weight	13 oz. (368.5 g)	

**Environmental**

Parameter	Value
IEC 60945 Classification	Exposed
Degree of Protection	IP64
Operating Temperature	-25°C to 55°C
Storage Temperature	-40°C to 70°C
Relative Humidity	93%RH @40° per IEC60945-8.2
Vibration	2-13.2Hz @ ±1mm, 13.2-100Hz @ 7m/s² per IEC 60945-8.7
Solar Radiation	Ultraviolet B, A, Visible, and Infrared per IEC 60945-8.10
Corrosion (Salt Mist)	4 times 7days @ 40°C, 95%RH after 2 hour Salt Spray per IEC 60945-8.12
Electromagnetic Emission	Conducted and Radiated Emission per IEC 60945-9
Electromagnetic Immunity	Conducted, Radiated, Supply, and ESD per IEC 60945-10
Safety Precautions	Dangerous Voltage, Electromagnetic Radio Frequency per IEC 60945-12



Copyright 2009 Maretron, LLP. All rights reserved. As Maretron is constantly improving its products, all specifications are subject to change without notice. Maretron's products are designed to be accurate and reliable; however, they should be used only as aids to navigation and vessel monitoring, and not as a replacement for traditional navigation and vessel monitoring techniques. A prudent captain or navigator never relies on a single source for navigation or system monitoring information. "NMEA 2000" is a registered trademark of the National Marine Electronics Association.