

ALM100 *Alarm Module*

Maretron's Alarm Module generates visual and audible alerts for any monitored condition. The Alarm Module includes an extremely loud 105 dB SPL Piezoelectric sounder, along with a red high-brightness LED to indicate an alarm condition. A second green LED indicates that the Alarm Module is powered and ready to be triggered. The audible alarm can sound any one of 32 distinct pre-programmed patterns to indicate different alerts. The Alarm Module can be triggered by alarms generated by Maretron's N2KView® Vessel Monitoring System, or by Maretron's DSM250 Color Graphics Display. The Alarm Module mounts in a standard electric box or can be flush mounted on any surface. Completely waterproof, the Alarm Module can be mounted inside or outside the vessel.



- NMEA 2000® Network Interface
- Super loud 105dB audible alarm
- Bright Red LED visual alarm
- Green LED status indicator
- Mounts in standard electrical wall box or flush mount directly in wall
- 32 selectable alarm patterns
- Waterproof - Can be mounted indoors or outdoors

Products

PART NUMBER	DESCRIPTION
ALM100-01	Alarm Buzzer with Black Cover Plate
CP-BK-ALM100	ALM100 Black Cover Plate
CP-WH-ALM100	ALM100 White Cover Plate

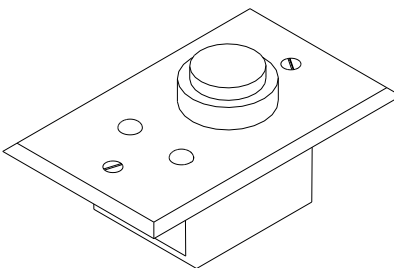
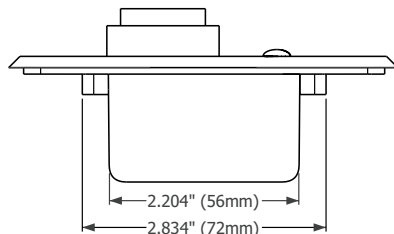
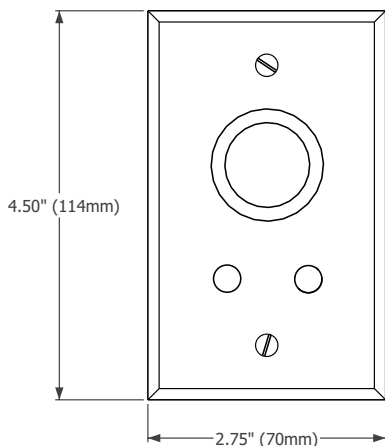

Specifications
Certifications

NMEA 2000® Parameter Group Numbers (PGNs)

Parameter	Value	Comment
Annunciator Volume	105 dB SPL	Mechanical Volume Control
Annunciator Frequency	2.9 kHz	

Standard	Comment
NMEA 2000® Standard	Level A
Maritime Navigation and Radio Communication Equipment & Systems	IEC 61162-3
Maritime Navigation and Radio Communication Equipment & Systems	IEC 60945
FCC and CE mark	Electromagnetic Compatibility

Description	PGN #	PGN Name	Default Rate
Periodic Data PGNs	128720	Proprietary Alarm Status*	1 time/second
	126464	PGN List (Transmit and Receive)	N/A
	126996	Product Information	N/A
Response to Requested PGNs	126998	Configuration Information	N/A
	059392	ISO Acknowledge	N/A
	059904	ISO Request	N/A
Protocol PGNs	060928	ISO Address Claim	N/A
	065240	ISO Address Command	N/A
	126208	NMEA	N/A
	128720	Configuration	N/A
	Maretron Proprietary PGNs	128720	Configuration

*Future firmware updates will allow the ALM100 to be in conformance with the upcoming NMEA 2000 alarm messaging protocol, once it is defined.

Electrical
Mechanical

Parameter	Value	Comment
Operating Voltage	9 to 32 Volts	DC Voltage
Power Consumption	100 mA	NMEA 2000 Interface
Load Equivalence Number (LEN)	2	NMEA 2000® Spec. (1LEN = 50 mA)
Reverse Battery Protection	Yes	Indefinitely
Load Dump Protection	Yes	Energy Rated per SAE J1113

Parameter	Value	Comment
Size	2.75" x 4.50" x 2.00" (70mm x 114mm x 51mm)	Including wall plate – Mounts in standard single-gang electrical box
Weight	13 oz. (368.5g)	

Environmental

Parameter	Value
IEC 60945 Classification	Exposed
Degree of Protection	IP67
Operating Temperature	-25°C to 55°C
Storage Temperature	-40°C to 70°C
Relative Humidity	93%RH @40° per IEC60945-8.2
Vibration	2-13.2Hz @ ±1mm, 13.2-100Hz @ 7m/s² per IEC 60945-8.7
Rain and Spray	12.5mm Nozzle @ 100liters/min from 3m for 30min per IEC 60945-8.8?
Solar Radiation	Ultraviolet B, A, Visible, and Infrared per IEC 60945-8.10
Corrosion (Salt Mist)	4 times 7days @ 40°C, 95%RH after 2 hour Salt Spray Per IEC 60945-8.12
Electromagnetic Emission	Conducted and Radiated Emission per IEC 60945-9
Electromagnetic Immunity	Conducted, Radiated, Supply, and ESD per IEC 60945-10
Safety Precautions	Dangerous Voltage, Electromagnetic Radio Frequency per IEC 60945-12

